

# Specialty Chemical Plant Migrates to SIMATIC PCS 7 Control System



process  
AUTOMATION

A specialty chemical plant located in the Southeastern United States needed to implement an effective DCS life-cycle management program to maintain their competitive advantage in the marketplace. The plant, in operation for over 25 years, produces a chemical that is used as a feed additive for helping farmers to deliver food to the table in a more efficient and environmentally friendly way.

Efficiency and an obsession for quality in the automated production process have also made this plant one of the most profitable for the company, a global market leader in specialty chemicals.

**Defining the Leading Edge**  
Over the past 25 years, the manufacturer has continually upgraded the plant to stay ahead of its competition.

In the early 80s, the automated production process at the facility was controlled by Moore Products' Multiloop Controllers (MLC). In 1992, the company was among the first to install a Moore APACS control system. By 1996, the APACS system grew to become the primary distributed control system (DCS) in the plant. The plan was to completely replace the MLCs with APACS equipment running on ProcessSuite Human Machine Interface (HMI) software.



Four years ago, the plant's project engineer began another upgrade to keep the facility at the leading edge of technology - to Siemens SIMATIC® PCS 7 distributed control system. The migration focused on leveraging the Siemens PCS 7 OS HMI to provide a common platform to operate and control the PCS 7, APACS, and QUADLOG controllers to minimize the total cost of ownership of the system and improve efficiency. This approach allowed the engineer to retain the valuable APACS hardware that will be used to run the plant for years to come.

Siemens is the only company that offered a comprehensive migration plan that fit the plant's needs. The proposed plan included maintaining existing hardware and preserving/reusing their intellectual property (control and HMI applications) helping to make the project economically viable.

The plan helped the project engineer convince the plant's production manager, engineering manager, and corporate finance people that the PCS 7 system was right for them.

At the time, the plant was well into the migration from the MLCs to the APACS control system with ProcessSuite HMI. Sixty percent of the MLCs were already changed. Forty percent of the HMI graphics had to yet be modified to complete the changeover.

Putting all the numbers in front of everybody and looking at where they were going, PCS 7 was the obvious choice, because the plant would have an HMI that worked with all the automation equipment. From a long-term perspective, the company would not have to go through another upgrade again for quite a while.

The migration to PCS 7 includes two redundant pairs of PCS 7 417 controllers and PCS 7 OS HMI servers located in a central control room. The upgrade is being performed in phases to not interrupt production. The system will retain the plant's existing 5 APACS controllers, 3 QUADLOG safety controllers, and approximately 3,500 redundant I/O including analog outputs.

#### **Graphics Conversion Sets Pace**

The company utilized Siemens graphics conversion service to automatically convert the existing graphics from its ProcessSuite HMI application to PCS 7 OS graphics. A total of 120 process graphics have been converted so far. The plant engineer said since he was not forced to re-engineer the HMI from scratch, using the conversion service has helped streamline the migration process while simultaneously lowering engineering costs.

The customer sent the old graphics to Siemens one day and received the converted versions back the next day. The majority of the 120 graphics were reproduced for \$8,000. The company tried to use as few graphics as possible in the application, which meant that each screen was packed with information. Normally, it would have cost about \$1,000 per graphic if the company engineered it themselves. By using Siemens graphic conversion service, it saved approximately \$112,000.

The improved and more intuitive HMI graphics will help the operators run the plant more effectively in the future. Operators will take advantage of the advanced functionality of the PCS 7 OS HMI, including a tool set for alarm management. Operations personnel are enabled to control the plant more efficiently, increase uptime, and improve predictive maintenance.

The plant's upgrade to PCS 7 technology is a good example of how effective life-cycle management of installed DCS systems doesn't have to be a painful proposition. Any control system migration should minimally impact the operator.

To minimize unplanned downtime, it is important to create an environment where common operational philosophies, procedures, and techniques are practiced across the board.

The concept is to design the operator interface so it works the same when connected to any control system. Even though underlying control systems perform different functions and are from different vintages, they should all appear seamless to the operator.

### New Engineering Tools Speed Development

The company also took advantage of several advanced engineering tools from Siemens to make the migration go smoothly and on time.

The APACS Library for PCS 7 made it easy for the engineers, who were very familiar with APACS, to configure the PCS 7 system in a way that was consistent with the APACS control system.

By using the APACS Library, the company could use function blocks in the PCS 7 controllers that were familiar to the engineers, operators, and maintenance personnel. That allowed it to have similarity with the control functions since the blocks had the same form, function, and naming conventions as when they were used in APACS. It all looks the same on the HMI. The library is a way of getting everyone on the same page. Even though they had a new controller and new engineering tools, operators didn't have to learn a new set of function blocks. In general, it is a good way to keep things consistent and to minimize the learning curve.

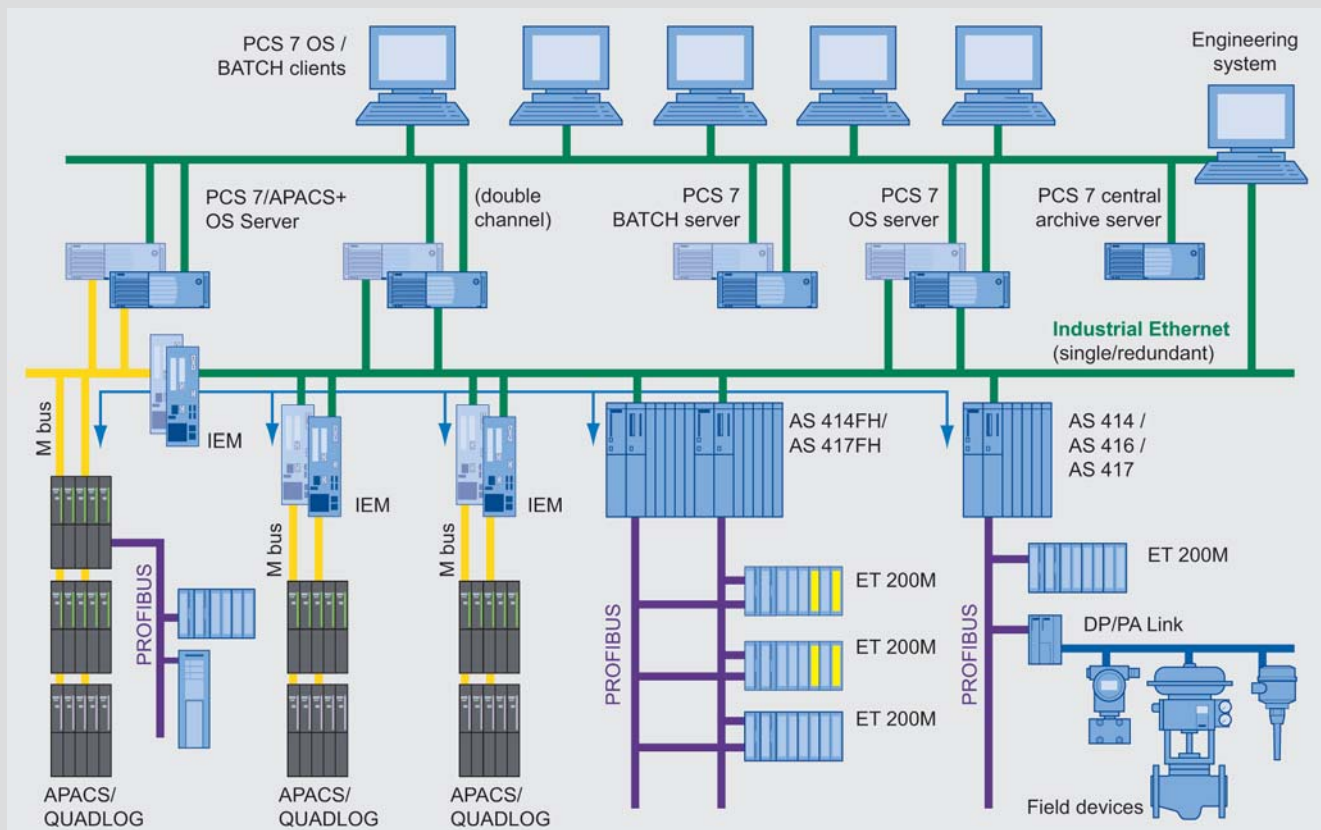

Typical Architecture for APACS+ Migration to PCS 7.

Another tool utilized by the plant during the migration process was Siemens Database Automation Utility. This tool allowed the project engineer to automatically generate the graphical dynamic elements, including symbols and faceplates, directly from the APACS controller configuration. This sped up the tagging and linking of the HMI to the control system, minimizing configuration mistakes and potential rework.

Siemens Import Export Assistant bulk engineering tool was also used to clone standardized elements of the control strategy (PID controllers, motors, valves) to minimize engineering costs and prevent configuration mistakes. This was especially useful when moving the control strategy from the MLC controller to the new PCS 7 controller. The company moved more than 50 loops per day from the MLC controller to the PCS 7 controller, including all parameters such as alarm limits and tuning coefficients.

#### Smart MCC

The project engineer says another important facet to the successful plant upgrade involved replacing a lineup of 25-year-old motor control centers (MCC) with Siemens smart MCC technology. In the past, he says random trips were common and MCC spare parts were difficult to find. He says the switch to Siemens TIASTAR MCCs with SIMOCODE-DP motor protection and control will help the plant reduce downtime and enhance predictive maintenance.

The TIASTAR MCCs are connected via PROFIBUS to the redundant PCS 7 417 controllers. The information brought directly into the PCS 7 OS HMI includes data not usually available through a distributed control system, including run time, temperature, current draw, number of trips, as well as alarm management, diagnostic, and historical statistics.

The information from the smart MCCs helps the operators look more closely at processes, avoid the distractions of annoying trips, and pay attention to more important issues.

Today, the plant has 30 motors communicating via PROFIBUS to PCS 7 controllers. Since the transition to the new TIASTAR MCCs, there have been no operational issues or nuisance tripping. When the plant migration is complete, even greater improvements in plant uptime and preventative maintenance are expected.

#### Teamwork Pays Off

In summarizing the migration to PCS 7 distributed control system technology, the manufacturer has developed a strong relationship with Siemens migration experts and has come to expect good service and quick response.

Looking at all the factors the company considered when deciding which automation company to go with, the biggest one is that Siemens had a solid migration strategy. Siemens had an HMI, a plan to put it in place on top of APACS to leverage the existing investment, and a program to move forward.

