

SIMOREG DC Master

6RA70 Series

Microprocessor-Based Converters from 6kW to 1900kW
for Variable-Speed DC Drives

Application

Continuous Operation during
a Pulse Generator Fault



NOTE

This application documentation does not purport to handle or take into account all of the equipment details or versions or to cover every conceivable operating situation or application. If you require more detailed information, or if special problems occur, which are not handled in enough detail in this document, please contact your local Siemens office.

The contents of this application documentation are not part of an earlier or existing agreement or legal contract and neither do they change it. The actual purchase contract represents the complete liability of the A&D Variable-Speed Drives Group of Siemens AG. The warrant conditions, specified in the contract between the two parties, is the only warranty which will be accepted by the A&D Variable-Speed Drives Group. The warranty conditions specified in the contract are neither expanded nor changed by the information provided in this application documentation.



WARNING



These converters contain hazardous electrical voltages and control rotating mechanical components (drives). Death, serious bodily injury or substantial damage to property will occur if the instructions in the relevant operating manuals are not observed.

Only qualified personnel who are thoroughly familiar with all safety notices contained in the operating instructions as well as erection, operating and maintenance instructions must be allowed to work on these devices.

Successful and safe operation of this equipment is dependent on careful transportation, proper storage and installation as well as correct operation and maintenance.

The reproduction, transmission or use of this document or contents is not permitted without express written authority. Offenders will be liable for damages. All rights, including rights created by patent grant or registration of a utility model or design, are reserved.

We have checked that the contents of this publication agree with the hardware and software described herein. Nonetheless, differences might exist and therefore we cannot guarantee that they are completely identical. The information given in this publication is reviewed at regular intervals and any corrections that might be necessary are made in the subsequent printings. Suggestions for improvement are welcome at all times.

SIMOREG ® is a registered trademark of Siemens

0 Contents

	Page
1 Applications	4
2 Parameter Settings	5
3 Simplified Block Diagram	6
4 Adjustments	7

1 Applications

In some critical processes the converter must not be switched off if a pulse generator or tachometer fault occurs. If a fault occurs on the speed actual-value sensor, the device must remain in operation and automatically switch to the calculation of the speed actual value as a substitute for the speed actual value signal. The calculated speed actual value is based on the measured armature voltage and the motor flux.

This application document describes the parameter setting required to implement the above application in the SIMOREG DC Master series 6RA70 using free function blocks in the software. For this, you require the technological software in the basic unit option S00.

If the calculated speed actual value is used instead of the encoder signal, parameter set 2 is used in order to be able to set the speed controller and the actual value filtering optimally.

Necessary connections

A signal from terminal 46 indicates that the calculated EMF is being used in the SIMOREG device.

Precondition

A pulse generator or an analog tachometer are required if the system is to be operated in the field weakening range. This actual-value sensor is required to acquire the field characteristic during start-up and determine the field current above the flux. (P051 = 27). As soon as the field characteristic has been recorded, the speed can be calculated both for the armature voltage range and for the field weakening range.

2 Parameter Settings

The parameter settings below configure the SIMOREG in such a way that as soon as an encoder error occurs, a calculated speed actual value is automatically activated by the actual-value sensor for closed-loop control purposes.

P083	=	4	Selects the source of the speed actual value from the free source via P609
P609	=	9210	Selects the output of free changeover switch 1 as the source of the actual value.
U145.01	=	287	Links the motor emf with the 1st divider input.
U145.02	=	290	Connects the motor flux with the 2nd divider input
U150.01	=	9145	Connects the output of the divider to the input of a multiplier.
U150.02	=	401	Connects a fixed signal (P401) to the multiplier input.
P401	=	67%	Scales the calculated speed as a function of the speed actual-value sensor
U240.01	=	40	Connects the pulse generator input to the free changeover switch
U240.02	=	9150	Connects the calculated speed to the free changeover switch
U241	=	9580	Configures B9580 as "Operate changeover switch"
U210.01	=	9120	Connects the pulse generator emf deviation to the limit monitor
U210.02	=	403	Connects P403 to the limit monitor as a comparison value
U212	=	0.5%	Hysteresis of the limit monitor
P771	=	9580	Connects the limit monitor output to terminal 46
U441	=	0.010 s	Selects an output delay time for the tachometer error
U440	=	9182	Selects limit monitor output as the input for the time delay
P676	=	33	Selects the limit monitor output as parameter set switchover
U120.01	=	9151	Connects the negative absolute value of the emf with the summator
U120.02	=	41	Connects the + absolute value of the pulse generator with the summator
U135	=	286	Connects the absolute value of the emf with the inverter
U151.01	=	244	Connects the output of the inverter with the multiplier for scaling
U151.02	=	402	Connects P402 with the multiplier for scaling
P403	=	-2	Limit value for tachometer error detection
P402	=	67	Scales emf to the same dimension as the pulse generator input
P200.02	=	50 ms	Speed actual value filter for parameter set 2
P820.10	=	42	Suppresses tachometer error
P820.11	=	48	Suppresses pulse generator errors

3 Simplified Block Diagram

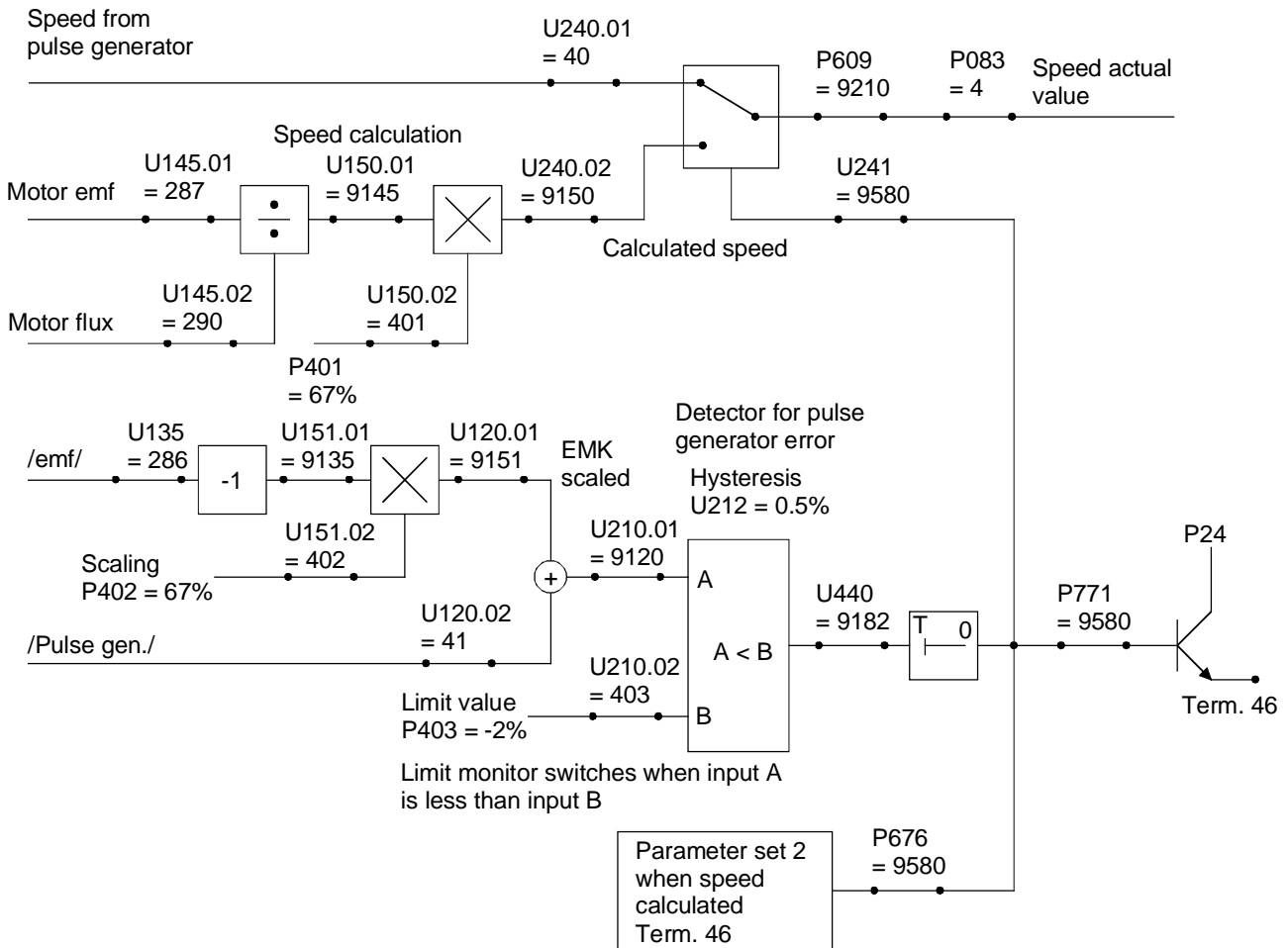

4 Adjustments

- ◆ Start up the drive in the normal way using the pulse generator evaluation. If necessary, perform a speed controller optimization run.
- ◆ As soon as the drive is operating correctly with the pulse generator evaluation, make the parameter settings as described in Section 2.

Speed calculation:

- ◆ Temporarily set the following parameters:

P044.01 = 40
P044.01 = 9150

You can now view the speed via the pulse generator via parameter r043.01 and the calculated speed via r043.02.

- ◆ Operate the drive at approx. 50% speed and check whether r043.01 and r043.02 match. If necessary, adjust P401 until r043.01 and r043.02 match.
- ◆ Run different speeds and check that r043.01 and r043.02 follow each other.

Tachometer break detector:

- ◆ Temporarily set the following parameter:

P044.03 = 9120

The difference between the pulse encoder signal and the scaled emf value can now be displayed when r043.03 is set.

- ◆ Operate the drive at approx. 50% speed in order to verify that r043.03 is almost 0%. If necessary, adjust P402 so that r043.03 is almost zero. If r043.03 becomes more negative than the quantity set in P403, the tachometer error switchover is activated.
- ◆ Use the parameter set copy function with P055 to copy parameter set 1 to parameter set 2.
- ◆ Temporarily set U241 = 1 to switch to the calculated speed.
- ◆ Set P200.02 = 50 ms in parameter set 2
- ◆ Optimize the speed controller. If necessary, also use the speed optimization run with P051 = 26. This allows independent parameters for pulse generator operation and operation at the calculated speed for the speed controller.
- ◆ Check that the drive is operating satisfactorily with the calculated speed actual value.
- ◆ Set U241 = 9580
- ◆ Operate the drive (it should operate with pulse generator evaluation). Parameter r056 should indicate that parameter set 1 is active (pulse generator mode). Parameter set 2 is used for the mode with the calculated speed.
- ◆ Disconnect the pulse encoder lead to simulate a pulse generator error and check that the drive switches to the calculated speed. A slight difference in speed will occur during switchover but the speed will return to its normal level with the calculated speed as the actual value. r056 should show that parameter set 2 is active.

