

# Arc Fault Detection and Discrimination Methods

Carlos E. Restrepo

Siemens Energy and Automation  
Residential Product Division  
5400 Triangle Parkway  
Norcross, GA 30092  
[carlos.restrepo@siemens.com](mailto:carlos.restrepo@siemens.com)

**ABSTRACT**—Arc waveform characteristics can be evaluated with various methods to recognize the presence of hazardous arc fault conditions. Discussion covers the arc phenomena and how it is generated in a low voltage electrical distribution circuit, as well as the isolation of the presence of hazardous conditions versus conditions that could falsely mimic the presence of an arc fault. Many waveform characteristics and conditions support the detection of hazardous arc faults and foster a more robust design, capable of withstanding unwanted tripping conditions.

*Keywords:* Arc Fault, Arcing, AFCI, Power Line Noise, Residential Circuit Breaker.

## I. INTRODUCTION

Electrical arcing conditions occur regularly in many electrical circuits. The majority of these conditions can be considered to be “safe” or controlled, occurring in environments designed to operate safely and withstand such arcs. Arcing defined by UL under the 1699 Standard is “a luminous discharge of electricity across an insulating medium, usually accompanied by the partial volatilization of the electrodes”. UL also defines an arcing fault as “an unintentional arcing condition in a circuit” so as to distinguish this from devices that arc as part of their normal operation.

Common loads and components found in a typical residential branch circuit manifest arcing conditions. For example, there are visible small and repetitive bursts of sparks in loads with brush motors and relays, such as drills and vacuum cleaners. The intensity of those arcs becomes greater as the motor is conditioned and exercised towards its end of life. On the other hand, there are situations that could potentially lead to serious arcing conditions, causing fires through the ignition of combustible materials or gases present while an arc fault is occurring.

In 2006 the United States Fire Administration (USFA), a part of the Department of Homeland Security, reported that 67,800 residential fires were related to electrical problems resulting in 485 deaths, over 2,300 injuries and \$868 million in property losses. The USFA also states that home electrical wiring causes twice as many fires as electrical appliances [1]. One of the major reasons for such issues arcing faults. These arcing faults can be generated from loose wire connections, cut insulation, etc. The need to improve the level of safety in the home has prompted institutions like the Consumer Product Safety Commission (CPSC), National Association of State Fire Marshals (NASFM), the Department of Housing

and Urban Development (HUD), and National Electric Manufacturers Association (NEMA) to promote the implementation of higher safety requirements, such as Arc Fault Circuit Interrupters (AFCI). HUD has even recommended AFCI’s as one of many devices that can be used to prevent fire related, citing a 1999 CPSC report that recommends the use of AFCI’s to “prohibit or reduce potential electrical fires from happening”. [2] Beginning with the 1999 National Electrical Code (NEC), there have been requirements for the use of AFCI’s, capable of detecting arc faults limited by an available current of 75A or higher.

The adoption of AFCI has been challenged by groups and institutions such as the National Home Builders Association (NHBA) claiming that the technology has not been proven to be an effective solution to residential electric fires. [3] Nevertheless, arc fault detection technology has found acceptance as states and municipalities start to see the benefits of having AFCI’s required in new construction. Per the 2005 NEC, AFCI combination devices will be required in bedroom circuits beginning January 1, 2008. [4].

As the new requirements demand a combination device capable of detecting both series and parallel arcing, the operating environment of the branch circuit becomes an increasingly important consideration.

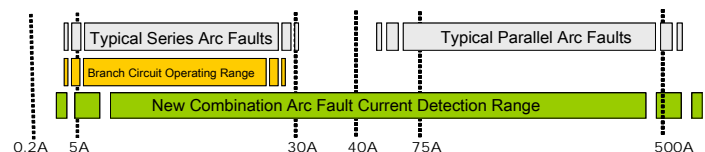

Figure 1. Comparison of Current Levels of Typical Series and Parallel Arc Faults, Normal Operation Range, and Combination AFCI Device Range.

The considerations for a branch/feeder AFCI require only that the device detect conditions that could be considered above its operating range of 0 to 20 Amperes. In the presence of a parallel arc fault the amount of current drawn by the branch circuit could be typically of 75A or higher, depending on the amount of current that is supplied to the entire house by the line source. Certain characteristics of these arc faults, such as sudden current transitions due to arc ignition after a zero-crossing of the AC source, can be shared with common devices in the home, like dimmer switches. The only difference is that the dimmers operate with currents below 30 Amperes while a parallel arc fault will tend to have

3 to 4 times that amount of current. The scenarios that could potentially make a branch/feeder design generate a nuisance tripping condition are restricted by high currents, such as in-rush conditions present in loads like compressors and lights.

The case of a Combination Type AFCI device requires having more intelligence to detect such arc faults. Series arcing current is bound by the loads connected to the branch circuit. This means that your faults could be as much as 110% of the rating of the particular branch. Therefore your device must be capable of properly discerning true arc faults versus potential nuisance conditions within a range of 5 to 30 Amperes, which covers everything you can plug in an outlet. As the normal operating range and portion of the detection range overlaps (Fig. 1), it becomes more of a challenge to discriminate between arc faults and nuisance conditions as well as potential situations where arcs could be masked by the presence of noisy loads.

Avoiding false positive reactions becomes important to the homeowner if the reaction causes loss of power to the entire branch circuit. Having to go down to the basement every time the living room lights and the vacuum cleaner are energized becomes bothersome quickly.

This rigorous balance can be achieved by understanding general aspects of arc faults (both series and parallel) and how they can be used to effectively discern when such hazardous conditions occur. Further discrimination based on specific aspects of arc faults and common loads can be implemented. These aspects will be discussed in further detail.

## II. ARC CONDITIONS [ARC CONDITIONS AND SAFETY]

Arcing is a well known phenomenon that can be described by Paschen's Law in most circumstances [5]. Two of the most important factors Paschen investigated in relation to the breakdown voltage needed to generate an arc were gas pressure and the gap distance between the electrodes. Some have found this empirical evaluation to be reflective of a very controlled environment. An alternating current (AC) environment has proven to depart significantly from Paschen's empirical analysis. Other aspects, like temperature, humidity and the condition of the electrodes, have also shown to be significant in affecting the generation of an arc fault [6]. Nevertheless, the conditions for sustainability of an arc can be established with less than an Ampere's worth of current.

Arc conditions can lead to an electric fire caused by exposing combustible material to the energy generated by the arc. This energy can be sufficient to cause wire insulation to decompose and char, generating combustible gases which become readily available to ignite. This chain reaction can be caused by as little as 200mA of current on a 120VAC circuit [7]. As arcing occurs, carbon deposits from the insulation can reside in the conductor and facilitate arcing to be more sustainable.

Situations occur that can lead to exposed line voltage capable of breaching the minimum air gap in a residential branch circuit. Poor connections between the conductor wire

and a receptacle or an accidental breach in the conductor during installation are two examples of precipitating situations. In some cases a single arc event may be harmless (in terms of causing a fire), but the repetition and sustainability of those conditions could provide all the right elements to create a hazardous condition and cause a fire.

On the other hand, there are arcing conditions that are expected and considered to be controlled, such as the operation of a light switch which generates arcing as it opens and closes a circuit. The severity of the arc depends on the mechanics of the design (opening and closing speeds, contact bouncing, contact material, etc.) and the load that the switch is operating. Even so, a switch mechanism beyond its useful life could be a precursor to a hazardous condition due to arcing.

In an effort to effectively detect potential safety hazards due to arcing, it is important to monitor those building conditions before they become hazardous. Duration of the arcing and its ability to self-sustain are critical aspects. Breakdown of the insulation and the generation of combustible gases can be caused by the increase in temperature due to arcing faults [7]. The temperature rise rate is also impacted by the amount of current flowing through the arcing connection.

The generation of a hazardous arcing condition results from a situation with developing stages from buildup to flame burnout. There has to be an initial source of arcing that will allow for a hazardous condition to originate.

The fault root cause is the single point that marks the initiation of a buildup that could lead to a hazardous arc fault. The root could be related to a loose connection or an accidental cut on the insulation while driving a nail through the wall. Other conditions could be the cause of stressing an extension cord by pressing on a single point with a heavy object and shearing strands of the wire. In addition these and other scenarios could all be propagated by misuse or abuse of the branch circuit. Situations like these could be easily overlooked or not noticeable which leads to the fact that they can be hard to detect initially. Applying best practices at the time of installation and proper use of the branch circuits in the home is important but cannot always be a guarantee that the possibility of arcing faults is eliminated.

During the buildup/conditioning stage, the weak point is conditioned mainly by the utilization of the branch circuit. A loose connection will tend to become looser as the thermal cycling expands and contracts the connection. A cut in a wire could start breaking down the insulation and potentially create carbon buildup around the conductors. The frequency and the amount of time the branch circuit is providing power will directly reduce (impact) the amount of time it will take for a hazardous condition to occur.

Once all the elements are in place and the circuit has been conditioned, the fault can manifest itself. A sustained arc fault will continue to overheat and generate a combustion that will consume all of the byproducts until arcing is interrupted or the flames have depleted all combustible resources.

### III. TYPES OF ARC FAULTS IN RESIDENTIAL CIRCUITS

As referred to earlier, arc faults in a branch circuit can be divided into two categories: series and parallel. A series arc fault occurs due to the interruption in the path of a conductor that is part of a circuit while a parallel arc fault occurs between conductors. Although the behavior of both faults is dictated by the same equations, the differences arise from the amount of current flowing through the arc. In a series arc fault, the amount of current available is dependent on the impedance (load). In a parallel arc fault, power source, not the load, dictates the amount of current capable of passing through the arc.

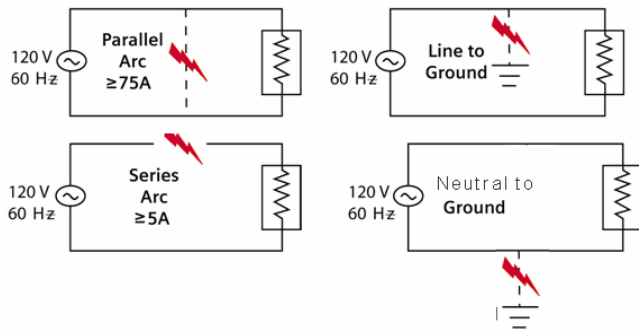

Figure 2. Description of Series and Parallel Arc Faults in a Residential Branch Circuit.

The amount of current passing through the circuit is sufficient to differentiate the behavior between the two types of faults which allows us to examine them separately. A parallel arc fault carries currents of approximately 75 Amperes or higher. Parallel arc faults will conduct all the current available from the supply side, limited only by the impedance of the conductors and elements that are part of the branch circuit. This also takes into account the impedance added by the thermal magnetic breaker designed to protect a 15-30 Amperes branch circuit. A series arc fault will typically carry currents within the margins of a branch circuit, limited by the impedance of the wires making the branch circuit and any load that is connected to the branch circuit. The arc faults that go across one conductor to the ground conductor are considered parallel faults.

### IV. CHARACTERISTICS

Arcing in the line can generate broadband noise as a product of the current flowing through. The broadband noise can propagate from the tens of hertz to 1GHz. The pattern of energy of that noise will seem more to fit that of pink noise [8].

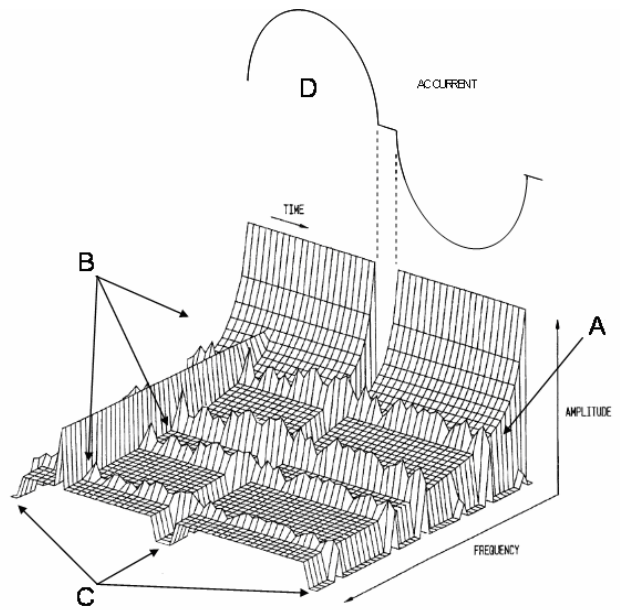

Figure 3. Description of the Frequency Spectrum of an Arc Fault through time [3]

In Fig. 3, **A** describes the broadband frequency spectrum generated by an arc fault. Broadband frequency noise generated by an arc fault follows a PINK noise pattern. As frequency increases the noise energy decreases. **B** indicates samples of discrete RF carriers along the spectrum that could be present in the branch circuit. **C** points out gaps in the frequency spectrum as a byproduct of the arc extinguishing near the zero-crossings region of the AC voltage. As the voltage approaches the zero crossing, the arc extinguishes itself and re-ignites when there is enough voltage to reestablish the arc across the conductors. **D** is a representation of the AC current waveform. Notice the correlation between the absence of current across the zero-crossings region and the absence of broadband energy across the spectrum.

Arc faults occurring in an AC environment (like a residential branch circuit) add an extra dimension that can be used to detect such conditions. An AC source changes with time periodically. For a residential circuit in the United States, the change is 120 Volts AC with a periodicity of 60 Hz.

The ability for an arc to sustain itself depends on the presence of certain resources. If we consider all the aspects needed for an arc fault to take place and add a variable power source, we find that the arc can change due to this variation. In a residential circuit, the arc will extinguish itself at the zero crossing of the AC source. Once there is not enough power, the arc will break and the flow of current will be interrupted. This interruption tends to be periodic, matching the periodicity of the AC source.

Information about the broadband noise and the periodicity of the source is significant in determining the presence of arcing conditions in a residential branch circuit. In addition there are other sources of noise which can be used to further increase the robustness of the design by reducing the tendency to detect false positives. One such source is a radio frequency (RF) coupled to a circuit.

### A. Broadband Noise

Arc faults generate broadband noise during current conduction. The spectrum of noise ranges from the tens of kilohertz to about 1GHz. In very consistent behavior, this noise is only present during the conduction of current while the arc is sustained, and the broadband noise disappears as soon as the arc is extinguished. Observations show that the level of energy contained in the broadband noise spectrum can be affected by the medium carrying the noise (the branch circuit) as well as by the amount of current that flows through the arc fault. The loss due to the branch circuit itself is about 60 db per 50 feet. The type of attenuation due to the amount of current is more indirect; the higher current is more violent and self-sustained arcs are more difficult to support. Also, higher currents create more ionization in the air gap, reducing the amount of broadband noise.

### B. Arc Fault Interruption and Periodicity

Broadband noise disappears as the AC source approaches the zero crossings. Once there is enough power, the arc can re-establish and re-extinguish based on the periodicity. This is an important discriminator since there is the possibility for noise in the line that is completely uncorrelated to the 60Hz.

### C. Arc Fault Current

All arc faults are dangerous and could potentially cause a residential fire. The higher the current the less time the circuit should be exposed to it before a fire can occur. As the current flowing through the arc increases, the chances of having a more aggressive arc fault condition increases. Large current arc faults are usually more violent and tend to disrupt the amount of time a fault can last. For example, a 500A arc fault could only last a couple of half-cycles while a 30A fault could last a couple of seconds.

## V. NON-HAZARDOUS ARCING

The ability for a device to detect series arc faults demands also the ability to separate true arc faults and potential false positives that can come from normal operation of the branch circuit. Typical household load can generate broadband noise correlated to 60Hz with enough current to meet all the criteria explained above and still not present any danger to the circuit.

In the case of parallel arc faults, the predominant conditions are related to the amount of inrush current produced by a particular load and further impacted by the ability of that load to “chop” the current like a triac would. The best load example to illustrate both conditions is the addition of 1000 watts of lights in a circuit which is controlled by a dimmer switch.

### A. Lights and Dimmers

Lights that have not been energized and are at room temperature, once turned ON, can generate large amounts of current until they settle to the normal power consumption. Typically 1000 Watts can generate 100A of peak current in the first couple of half-cycles and then decay to a steady state over 8 A RMS in an exponential fashion. A dimmer will affect the level of inrush and the rate of exponential decay of those lights to their steady-state value.

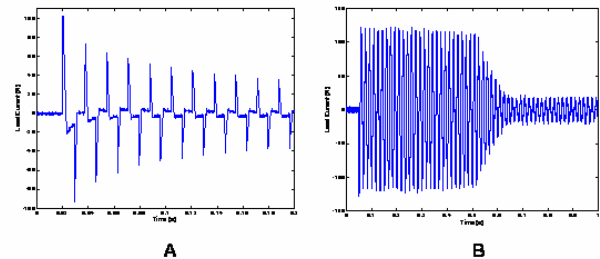

Figure 4. Current waveforms of (A) Dimmer Inrush and (B) Air Compressor.

In the case of a dimmer load causing an inrush (Fig. 4A), the AFCI device considers the first couple of half-cycles since they meet the sudden interruption and the required amplitude criteria. Once the current amplitude is below approximately 75A, those half-cycle events are not considered to be related to a high current parallel fault. In the case of high current arc fault of approximately 100 Amperes peak, a minimum of 5 half-cycle events is required in order to consider it an arcing fault. Due to the nature of the behavior, broadband noise is not used as the sole discriminator.

### B. Air Compressors

An air compressor is a typical motor load with initial startup inrush. The inrush tends to be roughly 150 Amperes peak and holds for about 200 to 500 milliseconds. Minimum amount of broadband noise is generated during the operation of this device. The peak current, however, is maintained for a significant amount of time even though it is not enough to be considered an over current condition which may take seconds to be detected by a thermal magnetic circuit breaker. The major difference from a true parallel arc fault is that there are no interruptions (purely sinusoidal) of the current.

### C. Vacuum Cleaners

Typically vacuum cleaners have an inrush of approximately 50 Amperes peak with an exponential decay that will reach a steady state within the 20 Amperes RMS. Regular vacuum cleaners carry one motor responsible for generating the suction power. These units rarely produce any consistent broadband noise and usually are not an issue because the inrush is low enough to avoid any confusion to an AFCI. Newer models have features that come with scrubbing mechanisms that employ very cost-effective and extremely noisy motors. The broadband noise is modulated by the periodicity of the line as an arc would be, but the persistence noise is not as uniform as that of an arc fault.

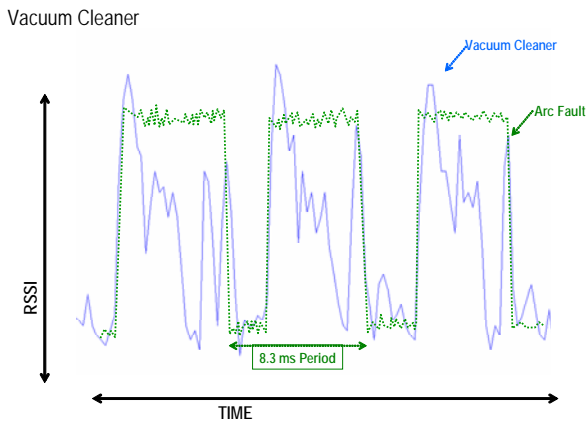

Figure 5. Description of a Vacuum Cleaner Load in Comparison to an Arc Fault

In the case of a noisy load like a vacuum cleaner, the persistence of broadband noise does not last through the whole half-cycle period of the line power. Series arc faults have the tendency to conduct fully until the power is not available to maintain it (at the zero-crossing regions) and to generate sustained broadband noise as a result of conducting current through the arc.

#### D. Electric Drills

Drills are the most common arcing loads available. The fact that drills arc during operation offers a challenge to AFCI devices, particularly those capable of detecting arc faults below 30A. Similar to genuine arc fault conditions, arcing inside the drill generates noise in the line strong enough to be detected by the broadband RF receiver. The major difference is that the arcing that takes place inside the drill is established and extinguished at a rate relevant to the revolutions per minute of the drill. The internal arcing does not have a direct correlation to the AC source since the arc breaks at each gap in the stator. When the speed of the drill is slow (closer to 60Hz), the arcs are extremely short lived and produce broadband noise that is not sustained through the longer portion of a 60Hz half-cycle. When the trigger is squeezed and the drill shows enough arcing, the correlation of the arcs is tightly coupled to RPM's and not to the periodicity of the line.

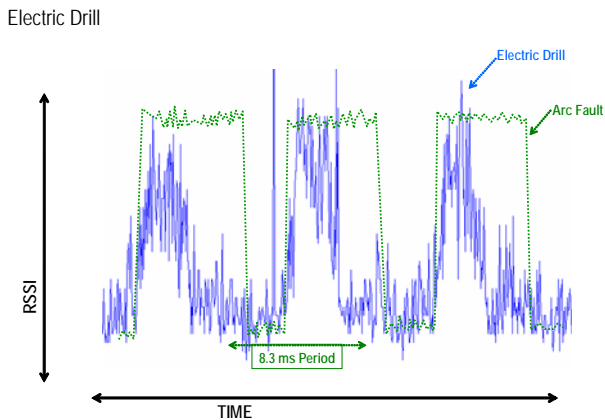

Figure 6. Description of the Broadband Energy of an Arc Fault and of an Electric Drill

#### E. Homeplug / Broadband over the Power Line (BPL)

Communication over the power line presents a huge challenge. This detection scheme employs high frequency/ high bit transmission strategies such as Orthogonal Frequency Division Modulation (OFDM) in the same frequency range (4-27MHz). Such interest in the same frequency range is driven by the impedance characteristics of the medium in addition to the availability of the frequency band. Information being broadcast in that frequency range could travel through the power line wire network of a home without significant degradation (150 – 200 ft).

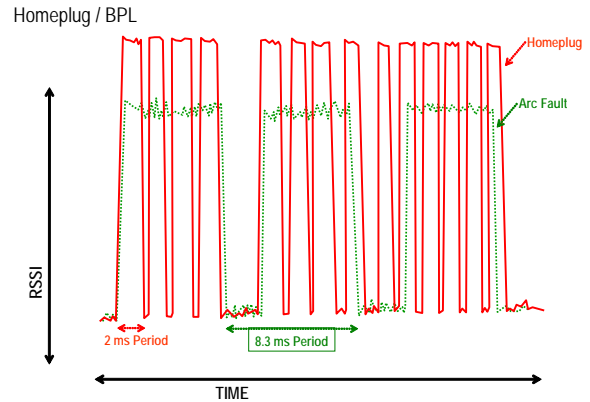

Figure 7. Description of Homeplug/Broadband over the power line vs. that of a typical series arc fault

As part of the specifications of the Homeplug standard, there is a restriction with regard to utilization time that avoids medium contention between nodes that are part of the Homeplug network. The maximum amount of packets transmitted without interruption by a node can amount to no more than 2ms of utilization time. After that there is a brief release period, and the next node has a chance to transmit. This period (or interruption) differs from that of an arcing condition since the Homeplug burst (during high traffic) can have a period of not more than 2ms and is not correlated to the line period.

#### F. RF Carriers in the Line

Single carriers picked by the wire connections in the home can easily be detected by the broadband RF receiver. The bandwidth of these carriers can be expected to be within 400 KHz and considered narrowband. The ability of the receiver to monitor the line across a wider band allows for these carriers to show momentarily as the receiver sweeps across a wideband for the presence of noise. The sweep rate is much higher than the periodicity of the line allowing for multiple sweeps across the wideband. Arc fault conditions tend to have a longer persistence while the receiver sweeps across the band since the presence of noise is broadband covering the whole spectrum. Single tone carriers can show momentarily as the receiver scans but disappear as the receiver is moving away from the fundamental carrier frequency.

## VI. POTENTIAL MASKING CONDITIONS

Beyond the need for a device that distinguishes between a real arc fault and a load that mimics such behavior, it is extremely important to address those conditions that could completely shadow a hazardous situation. The challenge applies more to those scenarios involving the presence of a series arc fault than parallel arc fault situations. The amplitude of current cannot be used as a strong differentiating characteristic since the amount of current in the circuit is within normal operation. The presence and periodicity of the noise become the factors to consider.

Noise in the line is expected but not to the extent of saturating the receiver at all frequencies selected within a detection spectrum bandwidth. FCC requires that electronic devices do not radiate or conduct emissions above a specified requirement. As long as this requirement is met, the amount of noise in the home should not present a masking condition.

### A. RF Behavior in the Line

The power line is not the optimal environment to transmit RF information. There have been multiple studies attempting to establish an impedance characteristic of home wiring. The characteristics of the impedance of home wiring circuits has been shown extremely variable, depending on the type of loads connected to it and the nature of the wiring itself. The variation of the RF (greater than 1MHz) impedance in the line ranges from 80 to 120 Ohms.

RF attenuation through the line is not uniform across the frequency spectrum. Even though an arc is capable of generating high frequency noise up to 1 GHz, a branch circuit will attenuate most above 50 MHz if the source of the arc is 50 feet away from the location of the AFCI. The optimum range is within 5-50 MHz which shows that it is not coincidence that Broadband over Power Line (BPL) operates in this range.

## VII. ARC FAULT DETECTION

### A. Series Arc Fault Detection

The detection method used for detecting series arcing consists of using AC load current information at 60Hz and its broadband RF content. Analog signal processing is done by an analog block (op-amps and transistors), and the output is a series of logic signals that are interpreted by a logic unit like a microcontroller.

A signal representative of the AC current from the line (Fig.8A) is used to generate a mask depicting the “zero crossing” region. The signal takes one logic state (1 or 0) when it is inside the zero crossing region, and it will take its inverse when the AC current is out of this region. The zero-crossing region can be defined as a time-bound region (or referenced) around the time where the AC current value is zero. The permanence inside this region can be limited to + or - ½ a half-cycle. (See Fig. 8D.)

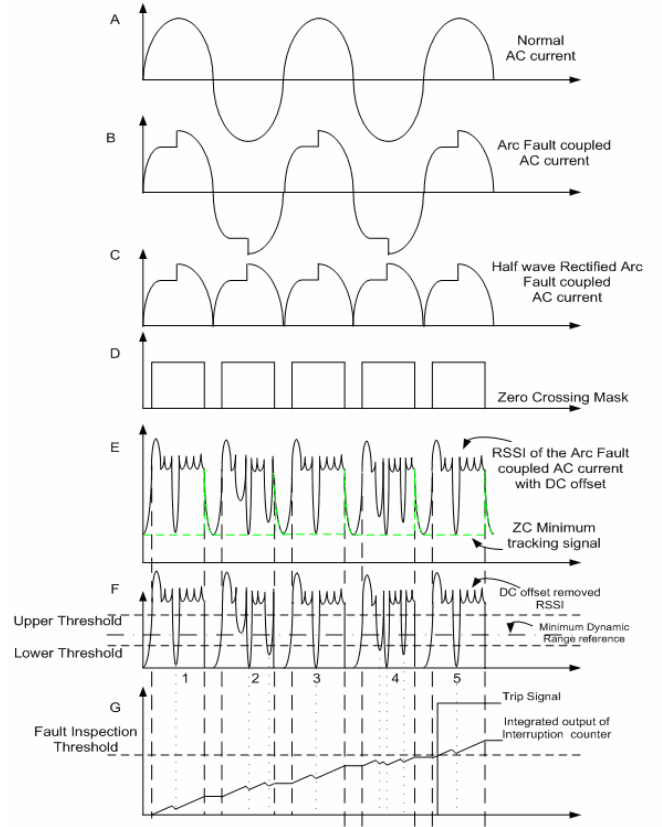

Figure 8. Description of Series Arc Faults being detected by this method.

Another signal representative of the energy of broadband RF present in the line is also provided by the RF receiver in the form of a voltage. This is known as the Received Signal Strength Indicator (RSSI) signal.

Due to potential noise issues this signal will have a baseline DC noise level associated with factors like electronics, AC line quality and other random conditions (Fig. 8E). Because of this variation, a portion of the analog circuitry takes the incoming RSSI signal and removes the DC Offset by the following method:

1. While inside the zero crossing region, track the minimum value and store it (or remember such value). This can be done with the use of a capacitor or a variable/register in software (if desired, inside a logic control unit).
2. Outside of the zero crossing region, subtract the recorded/memorized minimum to the original RSSI signal. Output of this operation is shown on Fig. 8F.
3. Reset minimum value inside the zero crossing region for the first time and repeat step 1.

This approach helps to differentiate signals that could cause nuisance trips. Some appliances can generate broadband RF that does not present gaps around the zero crossings. If the signal has a high RSSI level with no gaps or the gaps are not aligned with the zero crossing region mask signal, the minimum signal level tracked is close to the high RSSI values. Additionally, the difference between the RSSI values and the minimum level will be considered smaller

(Fig. 9F(4)) than that of a signal with arc-like characteristics (See Fig. 9F(2)).

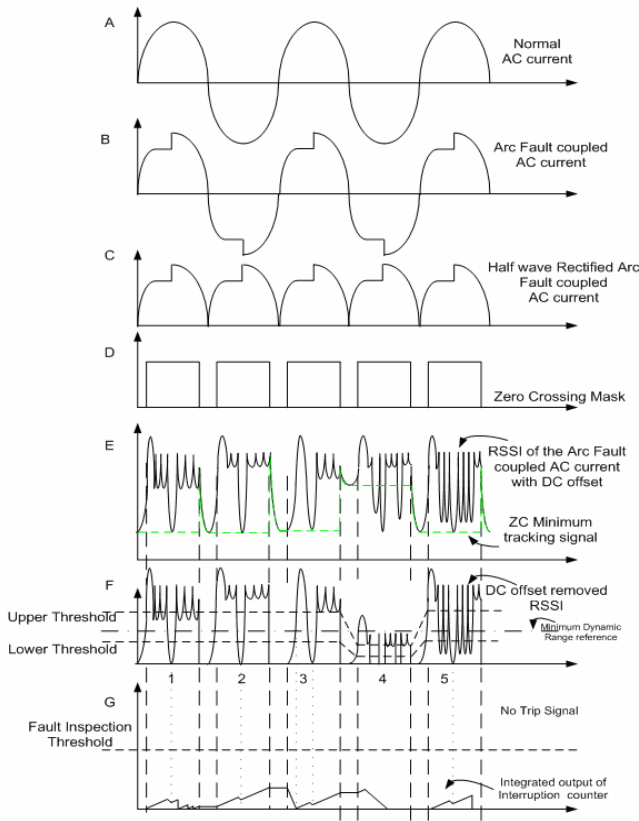

Figure 9. Signal Description of Nuisance Waveforms being tracked by this invention.

The RSSI without DC offset is then compared to three different threshold levels. Two levels are relative to the overall dynamic range of this RSSI signal, and one is an absolute reference. The absolute reference is used to make sure that the dynamic range of the modified RSSI is above a minimum set value. If this condition is not met, the evaluation of the other two thresholds will be meaningless. Only when this condition is met, the relative threshold comparisons' outputs will be based on the outcome of those comparisons. The last two thresholds represent a percentage (roughly 60% and 25% of the dynamic range). These comparisons are used to generate logical outputs that reflect whether the modified RSSI signal is above or below the respective threshold.

A condition that shows that the RSSI is above a given threshold will result in allowing an integrator (counter) to increment. If the condition shows that the RSSI is below such threshold, the counter will be decremented. In addition, a persistent transition from above to below the threshold will be considered "an interruption" of the RSSI signal outside the zero-crossing region. This interruption can be used as a further differentiator between arc faults and nuisance conditions.

An arc is considered to have a small number of "interruptions". The chaotic nature of the arc and the volatilization of

the contact points (due to the high temperatures) allow for small attenuation of the broadband RF byproduct of the arc. The numbers of interruptions allowed are set differently for each threshold. When the number of interruptions allowed is exceeded, the integrator is reset to an initial value which can be zero.

An arc fault is considered to be present in the protected branch when this integrator (counter) reaches above a set trip threshold.

There are two other logical outputs generated by this block. Both of them take the information of the RSSI, its first derivative, and a peak hold of that first derivative. These two signals are compared to thresholds, and each of them affects the counter in different ways. (See Fig. 4.)

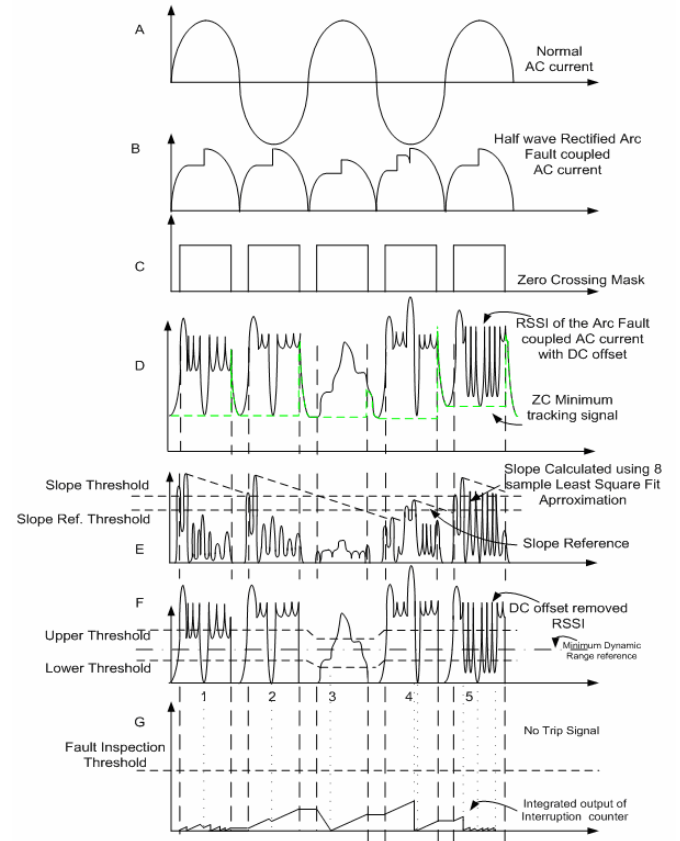

Figure 10. Slope Waveforms and how they affect the trip counter

If the peak hold signal of the first derivative of the RSSI is below a set threshold, then the counter is only allowed to decrement. If the first derivative signal is higher than the set threshold ONLY outside of the zero-crossing regions, then the integrator is set to an initial value (zero).

### B. Parallel Arc Detection

This portion of the arc fault detection circuit focuses on extracting information from the AC Load Current through the current sensor. In the case of parallel (i.e., high energy) arcs, their level of severity is determined by the available current of the branch circuit and not from load downstream. Arc faults of this kind tend to show characteristics such as sudden interruption of the current followed by high surge of

current (steep di/dt) and peak current amplitudes above normal operation levels. Here is a brief description of the major sub-blocks of this methodology of detection.

The load current signal is compared to a threshold. If the signal is above a threshold (75A and above), then this is considered as a characteristic of arc faults. The second characteristic used is the sudden interruption in arcing due to the extinguishing of the arc during the zero crossings. This can be easily examined by looking at the first derivative of the load current. If this first derivative is above a second threshold, then it is considered due to a potential arc fault. Both of these conditions must occur within  $\frac{1}{4}$  of the period the AC current to be considered an arc event.

Arc events are single half-cycles of an arc fault. The number qualifying the overall condition as an arc fault depends on the severity of the amplitude of arc events. In other words more arc events are needed if the amplitude of the arc is closer to the amplitude threshold (75A).

Once the circuit determines that there is an arc fault, it generates a trip signal that will activate a solenoid to open the contacts of the breaker. In the case of parallel arc faults from line to ground or neutral to ground, there is a differential current sensor used to determine the imbalance in the line which will generate a trip signal accordingly.

Series and parallel arc fault detection can be very different from each other. While the series arc fault heavily relies on broadband RF, the parallel arc fault involves high currents which provide less RF energy. The periodicity of the broadband noise follows the gaps of zero crossings. If related to the zero crossings, it is more likely that there is an arc fault present rather than a nuisance or a load that could resemble an arc fault. With parallel arc faults, we look for the presence of sharp edges on the current and high levels of current exceeding 75 A.

## VIII. CONCLUSIONS

As new safety requirements demand a more capable technology, there is an inherent challenge to evaluate the presence of arc fault conditions. The evaluative device must not be overly sensitive to conditions that could mimic arcing or those that actually arc without hazard. There are certain characteristics of true arc faults that can be used to ensure a proper methodology of detection. Sudden and periodic interruptions of current can be attributed to arc faults; the amount of current depends on whether the fault is series or parallel. The presence of broadband noise during arc faults is a key differentiator, and this condition diminishes as the amount of current through the arc fault increases, causing a higher level of ionization in the arc column. Further discrimination can be achieved by detecting interruptions that are not synchronous to the line power zero crossings.

## ACKNOWLEDGMENTS

The author would like to thank Siemens Energy and Automation, in particular the Residential Product Division for their support and commitment to the completion of this work.

## REFERENCES

- [1] [1] [USFA](#).2006. *On the Safety Circuit: A Factsheet on Home Electrical Fire Prevention*. United States Fire Administration
- [2] Healthy Home Issues: Injury Hazards, U.S. Department of Housing and Urban Development, version 3, March 2006
- [3] NFPA 70 Report on Comments NEC 2005 May 2004, and NFPA 70 Report on Proposals NEC 2005 May 2004.National Electric Code (NEC), 2005.
- [4] National Electric Code (NEC), 2005.
- [5] P.G. Slade, *Electrical Contacts*, Marcel Dekker, New York, NY, 1999, pages 438-445.
- [6] J. Slepian and R.C. Mason, "The Experimental Validity of Paschen's Law and of a Similar Relation for the Reignition Potential of an Alternating Current Arc," *Journal of Applied Physics* Vol. 8, Issue 9, pp. 619-621, Sept. 1937.
- [7] J. Shea, "Conditions for Series Arcing Phenomena in PVC Wiring," *Proceeding of the 51st Holm Conference of Electrical Contacts*, pp. 167-175, Sept. 2005.
- [8] F. Blades, "Method and Apparatus for Detecting Arcing in AC Power Systems by Monitoring High Frequency Noise," *United States Patent*, 5,729,145, Mar. 17 1998.
- [9] UL Standard for Safety for Arc Fault Circuit Interrupters, UL 1699, 2nd Edition. April 7 2006.
- [10] R. Dollar and W. Strickland, "Circuit interrupter including an electric arc monitoring circuit," *United States Patent*, 5,706,159, Jan. 6, 1998.

## AUTHOR BIOGRAPHY



**Carlos Restrepo** received a B.E.E. (1998) and M.S. in Electrical Engineering (2000) from the Georgia Institute of Technology. Prior to joining Siemens Energy and Automation he was involved in the Optical Telecommunications Industry developing purely optical re-transmission devices. He joined Siemens in 2001 as a product engineer responsible for developing electronic circuit breakers for the residential market. Currently he is an Engineering Manager for the Residential Product Division working on the development of new technology used for residential circuit protection, specifically, arc fault detection methodologies and applications.